

Quality Built Since 1947

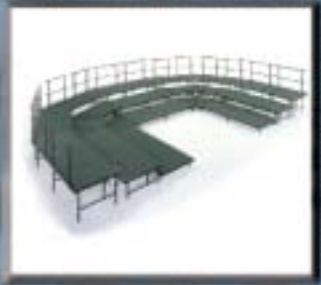

INSTITUTIONAL PRODUCTS

midwest FOLDING
PRODUCTS
A SAGUS INTERNATIONAL COMPANY

COLOR SELECTION

STANDARD LAMINATE FINISHES



STANDARD METAL FINISH COLORS



EDGE FINISHES

VINYL COLOR MOLDINGS



- Black
- Brown
- Gray
- Putty
- Blue
- Yellow

PREMIUM TOP OPTIONS



Perma-Tuff Edging

PREMIUM LAMINATE FINISHES

(Available at additional cost)

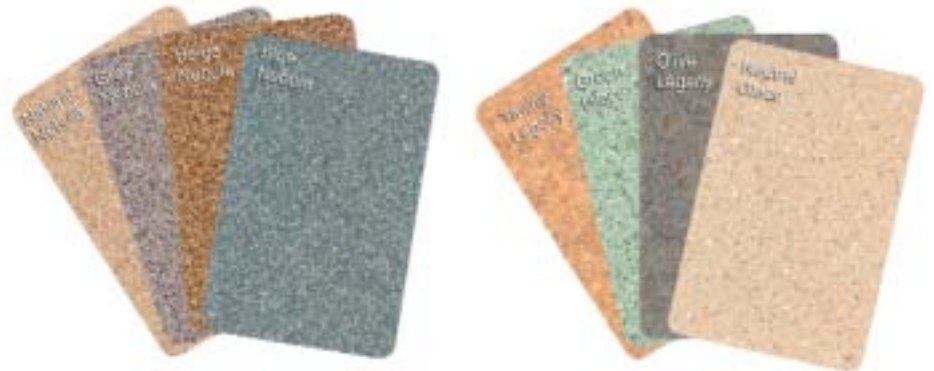

(Additional laminate selections are available upon request)

WARRANTY

EF, Designer Series Folding Tables	10 years
Stages and Risers	10 years
LW Series Folding Tables	5 years
Mobile Utility Tables	5 years
Heavy-Duty Table Caddies	5 years
FN, F, TL, TLA, FA Series Folding Tables	1 year
Activity Tables	1 year
Folding Benches	1 year
Standard Table and Stage Caddies	1 year
Folding Chair Caddies	1 year

Midwest warrants products purchased hereunder to be free of defects in materials and workmanship, from the date of shipment for the period of time as follows:

This warranty shall not apply in the event products are damaged as a result of misuse, abuse, neglect, accident, improper application, modification or repair by persons not authorized by Midwest, where the products are damaged during shipment, or where the date stamps on the product have been defaced, modified or removed, unless considered unenforceable or unlawful under applicable law. All implied warranties including, but not limited to, warranties of merchantability and fitness for a particular purpose are hereby excluded. Purchaser's remedy, if any, for any defective products shall be limited to a refund, replacement or adjustment by Midwest of the products at Midwest's option and shall, in no event, include damages of any kind, whether incidental, consequential or otherwise.



The plywood frame is literally the backbone of this time tested folding table design. Attractive high-pressure laminate, bonded to a sheet of tempered hardboard, provides a durable surface for many years of demanding use. Pedestal style legs feature a 1.05" diameter, 14 gauge steel tube base to support heavy loads without bending.

306FN

308FN

The **midwest** Advantage

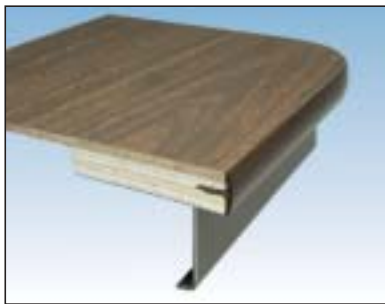

A plywood frame supported by a 16 gauge steel channel frame resists impact damage and carries heavy loads with ease.



Extra thick, 14 gauge steel leg base stands up to heavy use without bending. Non-removable, high impact plastic leg glides protect floors.



Leg braces incorporate spring loaded, case hardened steel detents for long life and fast set-up & tear-down.



Tops are reinforced against breakage with a square corner steel frame.

FN SERIES FOLDING TABLES

TABLE STYLE	MODEL No	SIZE W x L x H	WT LBS
RECTANGULAR 	305FN	30" x 60" x 29"	55
	306FN	30" x 72" x 29"	59
	308FN	30" x 96" x 29"	73
	366FN	36" x 72" x 29"	71
	368FN	36" x 96" x 29"	83

10
YEAR
WARRANTY



CP618EF



630EF



R60EF

The **midwest** Advantage

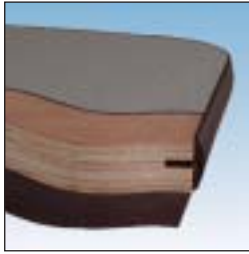

Solid 3/4" thick plywood is surfaced with high pressure plastic laminate, sealed with a backing sheet and edged with thick vinyl molding.



Tops are reinforced against breakage with a square corner steel frame.



Leg braces incorporate spring loaded, case hardened steel detents for long life and fast set-up & tear-down.



Extra thick, 14 gauge steel leg construction stands up to heavy use without bending. Non-removable, high impact plastic leg glides protect floors.

SPECIFICATIONS

TOPS - EF Series Tops are constructed of solid, 3/4" thick, AC grade, exterior glue plywood, surfaced with high pressure plastic laminate and backed with a phenolic sheet to prevent moisture penetration. Tops are edged with 3/8" thick, vinyl T-molding, secured with staples from the underside of the table top at regular intervals.

TOP SUPPORT STRUCTURE - Table tops are supported by a formed steel channel frame of 1 1/4" deep 16 gauge steel. Frames are secured to the table top with screws placed no greater than 10" apart.

LEG ASSEMBLIES - Leg assemblies are wishbone style, constructed with one-piece load bearing vertical members of 1.05" diameter, 14 gauge steel tubing. Each leg is capped with high impact plastic glides, secured with internal spring steel grippers. Tables less than 48" in length or diameter are furnished with independent folding legs of 1.05" diameter, 14 gauge steel tubing. *Comfort Leg* assemblies are constructed of 1 1/4" diameter steel tubing.

LEG BRACE MECHANISMS - Folding leg braces are constructed of 3/8" wide, 1/8" thick edge radiused steel. Coil-spring actuated, case-hardened steel detents engage mating holes in the brace to secure the brace automatically when it is opened. Leg braces are attached to leg assemblies and pivot bracket by the use of steel shoulder rivets.

METAL FINISH - All metal parts are thoroughly cleaned and phosphatized to enhance paint adhesion. Metal parts are then finished with a thermofused epoxy powder coating.

PREMIUM TOP OPTIONS



Aluminum Edge Molding

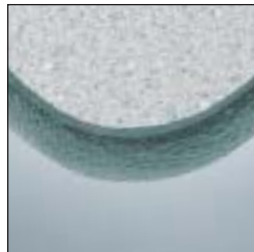

Perma-Tuff Edging
(with high pressure laminate backing)







Comfort Leg Seminar Table



Standard Leg Seminar Table

EF SERIES FOLDING TABLES

TABLE STYLE	MODEL No	SIZE W x L x H	Wt LBS
 RECTANGULAR	430EF	30" x 48" x 30"	47
	530EF	30" x 60" x 30"	55
	630EF	30" x 72" x 30"	62
	830EF	30" x 96" x 30"	77
	636EF	36" x 72" x 30"	76
	836EF	36" x 96" x 30"	86
 ROUND	R30EF	30" dia. x 30"	29
	R36EF	36" dia. x 30"	33
	R42EF	42" dia. x 30"	44
	R48EF	48" dia. x 30"	55
	R54EF	54" dia. x 30"	66
	R60EF	60" dia. x 30"	78
	R66EF**	66" dia. x 30"	81
R72EF**	72" dia. x 30"	87	
 GAME	SQ30EF	30" x 30" x 30"	36
	SQ36EF	36" x 36" x 30"	41
 STANDARD SEMINAR	518EF	18" x 60" x 30"	47
	618EF	18" x 72" x 30"	48
	818EF	18" x 96" x 30"	61
	524EF	24" x 60" x 30"	53
	624EF	24" x 72" x 30"	60
	824EF	24" x 96" x 30"	66
 COMFORT LEG SEMINAR	CP518EF*	18" x 60" x 30"	49
	CP618EF*	18" x 72" x 30"	50
	CP818EF*	18" x 96" x 30"	63
	CP524EF*	24" x 60" x 30"	57
	CP624EF*	24" x 72" x 30"	63
	CP824EF*	24" x 96" x 30"	70

*30" height available upon request.

**The laminate surface on these models is made from two pieces of plastic. A seam will be visible with all top colors, however, wood grain patterns help make seams less visible.





LW SERIES, lightweight folding tables are precision molded from durable, ABS plastic. Extra thick, extruded ABS bumper molding protects the edges against damage. Tables feature solid plastic, internal reinforced corners and spring-bolt actuated leg brace mechanisms. Standard models are furnished with wishbone style legs and are available in three standard plastic colors.

Specialty models are available in red, green, yellow and blue tops. Adjustable legs, that feature easy 1" height adjustment without the use of tools, are also available.





F SERIES FOLDING TABLES

TABLE STYLE	MODEL No	SIZE W x L x H	Wt LBS
SEMINAR 	518F	18" x 60" x 29"	48
	618F	18" x 72" x 29"	52
	818F	18" x 96" x 29"	63
	524F	24" x 60" x 29"	55
	624F	24" x 72" x 29"	62
	824F	24" x 96" x 29"	79
RECTANGULAR 	3060F*	30" x 60" x 29"	62
	3072F*	30" x 72" x 29"	72
	3096F*	30" x 96" x 29"	90
	3672F*	36" x 72" x 29"	82
	3696F*	36" x 96" x 29"	104
36" HEIGHT 	3072F36	30" x 72" x 36"	74
	3096F36	30" x 96" x 36"	92
	3672F36	36" x 72" x 36"	84
	3696F36	36" x 96" x 36"	106
ROUND 	R48F	48" dia. x 29"	63
	R60F	60" dia. x 29"	91
	R72F**	72" dia. x 29"	145
SQUARE 	SQ30F	30" x 30" x 29"	35
	SQ36F	36" x 36" x 29"	40

*Furnished with pedestal style legs.

**The laminate surface on these models is made from two pieces of plastic. A seam will be visible with all top colors, however, wood grain patterns help make seams less visible.

The **midwest** Advantage



Extra thick, 14 gauge steel leg construction stands up to heavy use without bending. Non-removable, high impact plastic leg glides protect floors.



Leg braces incorporate spring loaded, case hardened steel detents for long life and fast set-up & tear-down.



Tops are reinforced against breakage with a square corner steel frame.

SPECIFICATIONS

TOPS - F Series Tops are constructed of solid, 3/8" thick, 47lb industrial grade, particleboard, surfaced with high pressure plastic laminate and backed with a phenolic sheet to prevent moisture penetration. Tops are edged with vinyl T-molding, secured with staples from the underside of the table top at regular intervals.

TOP SUPPORT STRUCTURE - Table tops are supported by a formed steel channel frame of 1-1/8" deep 16 gauge steel. Frames are secured to the table top with screws placed no greater than 10" apart.

LEG ASSEMBLIES - Wishbone leg assemblies are constructed with one-piece load bearing members of 1.05" diameter, 14 gauge steel tubing. Pedestal style legs are constructed with base sections of 1.05" diameter, 14 gauge tubing and all other components being of 1" diameter, 16 gauge tubing. Legs are capped with high impact plastic glides, secured with internal spring steel grippers. Tables less than 48" in length or diameter are furnished with independent folding legs of 1.05" diameter, 14 gauge steel tubing.

LEG BRACE MECHANISMS - Folding leg braces are constructed of 3/8" wide, 3/8" thick edge radiused steel. Coil-spring actuated, case-hardened steel detents engage mating holes in the brace to secure the brace automatically when it is opened. Leg braces are attached to leg assemblies and pivot bracket by the use of steel shoulder rivets.

METAL FINISH - All metal parts are thoroughly cleaned and phosphatized to enhance paint adhesion. Metal parts are then finished with a thermofused epoxy powder coating.

Cafeteria Seating

FOLDING BENCHES

Folding benches offer an economical solution for your cafeteria seating needs. Benches may be folded quickly for compact storage. The sturdy frame and heavy-duty leg design provides safe seating for adults. A durable high-pressure laminate surface stands up to many years of frequent cleaning and constant use.



Model No: B6F Size: 12"W x 72"L x 18"H Wt: 37 lbs
 Model No: B8F Size: 12"W x 96"L x 18"H Wt: 50 lbs



TLA245

From the lecture hall to the boardroom, our TL Series folding tables are attractive, yet durable, with reliable performance that will fit your budget. The TL Series table is available with fixed or adjustable legs, appointed with decorative panels that match the top surface. Adjustable legs may be repositioned vertically in 1" increments to conform to the task at hand.



TLA245



TLA48R



TL306

TLA SERIES - HEIGHT ADJUSTMENT

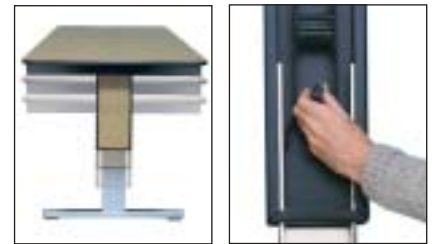

Vertical adjustment is accomplished quickly by pulling out on the spring loaded locking pin.

TL SERIES PLYWOOD CORE Fixed Height Models

TABLE STYLE	MODEL No	SIZE W x L x H	Wt LBS
SEMINAR	TL186EF	18" x 72" x 29"	57
	TL188EF	18" x 96" x 29"	67
	TL246EF	24" x 72" x 29"	68
	TL248EF	24" x 96" x 29"	78
	TL305EF*	30" x 60" x 29"	67
CONFERENCE UTILITY	TL306EF	30" x 72" x 29"	76
	TL308EF	30" x 96" x 29"	91
	TL366EF	36" x 72" x 29"	84
	TL368EF	36" x 96" x 29"	91

TL SERIES PARTICLEBOARD CORE Fixed Height Models

TABLE STYLE	MODEL No	SIZE W x L x H	Wt LBS
SEMINAR	TL185*	18" x 60" x 29"	58
	TL186	18" x 72" x 29"	62
	TL188	18" x 96" x 29"	73
	TL244*	24" x 48" x 29"	67
	TL245*	24" x 60" x 29"	71
	TL246	24" x 72" x 29"	74
	TL248	24" x 96" x 29"	87
CONFERENCE UTILITY	TL305*	30" x 60" x 29"	74
	TL306	30" x 72" x 29"	84
	TL308	30" x 96" x 29"	101
	TL366	36" x 72" x 29"	94
	TL368	36" x 96" x 29"	114

*Tables will not fold flat for stacking.

TLA SERIES PLYWOOD CORE

Adjustable Height Models

TABLE STYLE	MODEL No	SIZE W x L	TABLE HEIGHT OPTIONS			Wt LBS
			STANDARD	TLA-1	TLA-2	
SEMINAR	TLA186EF	18" x 72"	22"-29"	19"-26"	27"-34"	57
	TLA188EF	18" x 96"	22"-29"	19"-26"	27"-34"	67
	TLA245EF	24" x 60"	22"-26"	19"-26"	27"-34"	71
	TLA246EF	24" x 72"	22"-26"	19"-26"	27"-34"	68
	TLA248EF	24" x 96"	22"-29"	19"-26"	27"-34"	78
CONFERENCE UTILITY	TLA305EF	30" x 60"	22"-29"	19"-26"	27"-34"	67
	TLA306EF	30" x 72"	22"-29"	19"-26"	27"-34"	76
	TLA308EF	30" x 96"	22"-29"	19"-26"	27"-34"	91
	TLA366EF	36" x 72"	22"-29"	19"-26"	27"-34"	84
	TLA368EF	36" x 96"	22"-29"	19"-26"	27"-34"	91
ROUND	TLA48REF	48" dia.	22"-29"	19"-26"	27"-34"	60

TLA SERIES PARTICLEBOARD CORE

Adjustable Height Models

TABLE STYLE	MODEL No	SIZE W x L	TABLE HEIGHT OPTIONS			Wt LBS
			STANDARD	TLA-1	TLA-2	
SEMINAR	TLA186	18" x 72"	22"-29"	19"-26"	27"-34"	62
	TLA188	18" x 96"	22"-29"	19"-26"	27"-34"	73
	TLA244	24" x 48"	22"-29"	19"-26"	27"-34"	67
	TLA245	24" x 60"	22"-26"	19"-26"	27"-34"	71
	TLA246	24" x 72"	22"-26"	19"-26"	27"-34"	74
	TLA248	24" x 96"	22"-29"	19"-26"	27"-34"	87
CONFERENCE UTILITY	TLA305	30" x 60"	22"-29"	19"-26"	27"-34"	76
	TLA306	30" x 72"	22"-29"	19"-26"	27"-34"	84
	TLA308	30" x 96"	22"-29"	19"-26"	27"-34"	101
	TLA366	36" x 72"	22"-29"	19"-26"	27"-34"	94
	TLA368	36" x 96"	22"-29"	19"-26"	27"-34"	114
ROUND	TLA48R	48" dia.	22"-29"	19"-26"	27"-34"	68

If other than standard height is desired, height options TLA-1 or TLA-2 must be specified.

Comfort Leg tables for classroom, seminar and training facilities offer unobstructed knee space not available with other folding tables. Tables quickly fold for compact storage when required, yet are incredibly stable when opened for use. Conference/utility models look good enough for the boardroom, but their plywood core tops provide the durability to withstand many years of rough use.



CP618EF



CP518EF



DS630EF

PLYWOOD CORE TOP

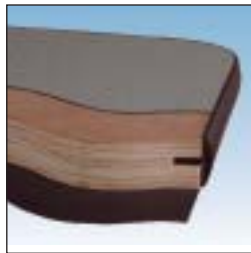

Solid 3/4" thick plywood is surfaced with high pressure plastic laminate, sealed with a backing sheet and edged with vinyl molding.

PREMIUM TOP OPTIONS



Aluminum Edge Molding





Perma-Tuff Edging

METAL FINISH COLORS



DESIGNER SERIES

TABLE STYLE	POWDERCOAT LEG FINISH	CHROME LEG FINISH	SIZE W x L x H	WT LBS
 COMFORT LEG SEMINAR	CP518EF	CS518EF	18" x 60" x 30"	49
	CP618EF	CS618EF	18" x 72" x 30"	50
	CP818EF	CS818EF	18" x 96" x 30"	63
	CP524EF	CS524EF	24" x 60" x 30"	5
	CP624EF	CS624EF	24" x 72" x 30"	63
	CP824EF	CS824EF	24" x 96" x 30"	70
 CONFERENCE UTILITY	DP530EF*	DS530EF*	30" x 60" x 29"	53
	DP630EF	DS630EF	30" x 72" x 29"	59
	DP830EF	DS830EF	30" x 96" x 29"	73
	DP636EF	DS636EF	36" x 72" x 29"	73
	DP836EF	DS836EF	36" x 96" x 29"	82
	 MODESTY PANELS	MP510		10" x 60"
MP610			10" x 72"	10
MP810			10" x 92"	13

30" height available upon request.

*Legs do not fold flat for stacking. Store on model TEC caddy. Modesty panels available only on 18" and 24" models.



A self-locking screw draws the leg insert tightly against the leg housing for a rigid connection. Leg inserts are chrome plated for durability and are adjustable in 1" increments



Formed steel I beams are furnished on all tables 60" and longer to prevent sagging.



Assembly is fast and easy. Simply slide the leg into the factory equipped mounting bracket and insert one screw to lock the leg in place.



Vinyl Bullnose edge



Optional PermaTuff polyurethane epoxy edge

PARTICLEBOARD CORE ACTIVITY TABLES

TABLE STYLE	SIZE W x L x H	Wt LBS	ADJ. HEIGHT CHROME LEG INSERTS MODEL No	29" FIXED HT POWDERCOATED LEGS MODEL No
Rectangular	24" x 36" x 22-29"	41	AA324F	AF324F
	24" x 48" x 22-29"	54	AA424F	AF424F
	24" x 60" x 22-29"	66	AA524F	AF524F
	24" x 72" x 22-29"	74	AA624F	AF624F
	30" x 48" x 22-29"	60	AA430F	AF430F
	30" x 60" x 22-29"	76	AA530F	AF530F
	30" x 72" x 22-29"	88	AA630F	AF630F
	30" x 96" x 22-29"	106	AA830F	AF830F
	36" x 60" x 22-29"	89	AA536F	AF536F
	36" x 72" x 22-29"	105	AA636F	AF636F
42" x 60" x 22-29"	113	AA542F	AF542F	
Round	36" dia. x 22-29"	48	AAR36F	AFR36F
	42" dia. x 22-29"	59	AAR42F	AFR42F
	48" dia. x 22-29"	74	AAR48F	AFR48F
	60" dia. x 22-29"	109	AAR60F	AFR60F
Square	36" x 36" x 22-29"	56	AASQ36F	AFSQ36F
	42" x 42" x 22-29"	76	AASQ42F	AFSQ42F
	48" x 48" x 22-29"	99	AASQ48F	AFSQ48F
1/2 Round	1/2 of 48" dia. x 22-29"	42	AAHR48F	AFHR48F

PARTICLEBOARD CORE ACTIVITY TABLES

TABLE STYLE	SIZE W x L x H	Wt LBS	ADJ. HEIGHT CHROME LEG INSERTS MODEL No	29" FIXED HT POWDERCOATED LEGS MODEL No
Trapezoid	24" x 24" x 48" x 22-29"	37	AATP424F	AFTP424F
	30" x 30" x 60" x 22-29"	51	AATP530F	AFTP530F
Kidney	48" x 72" x 22-29"	110	AAKY648F	AFKY648F
	48" x 96" x 22-29"	156	AAKY848F	AFKY848F
Horseshoe	60" x 66" x 22-29"	124	AAHS666F	AFHS666F
Clover	48" dia. x 22-29"	68	AAC48F	AAFC48F
Flower	60" dia. x 22-29"	105	AAF60F	AFF60F

Lower height tables that adjust from 17" to 25" are available upon request. Black metal finish and edge molding are standard. Tops are constructed of solid 47 lb industrial grade particleboard core, edged with vinyl bullnose molding and are 1 1/4" thick.

PLYWOOD CORE ACTIVITY TABLES

TABLE STYLE	SIZE W x L x H	WT LBS	ADJ. HEIGHT CHROME LEG INSERTS MODEL No	29" FIXED HT POWDERCOATED LEGS MODEL No
Rectangular	24" x 36" x 22-29"	30	AA324EF	AF324EF
	24" x 48" x 22-29"	39	AA424EF	AF424EF
	24" x 60" x 22-29"	49	AA524EF	AF524EF
	24" x 72" x 22-29"	55	AA624EF	AF624EF
	30" x 48" x 22-29"	60	AA430EF	AF430EF
	30" x 60" x 22-29"	45	AA530EF	AF530EF
	30" x 72" x 22-29"	55	AA630EF	AF630EF
	30" x 96" x 22-29"	66	AA830EF	AF830EF
	36" x 60" x 22-29"	67	AA536EF	AF536EF
	36" x 72" x 22-29"	77	AA636EF	AF636EF
42" x 60" x 22-29"	84	AA542EF	AF542EF	
Round	36" dia. x 22-29"	25	AAR36EF	AFR36EF
	42" dia. x 22-29"	41	AAR42EF	AFR42EF
	48" dia. x 22-29"	55	AAR48EF	AFR48EF
	60" dia. x 22-29"	81	AAR60F	AFR60EF
Square	36" x 36" x 22-29"	42	AASQ36EF	AFSQ36EF
	42" x 42" x 22-29"	58	AASQ42EF	AFSQ42EF
	48" x 48" x 22-29"	76	AASQ48EF	AFSQ48EF
1/2 Round	1/2 of 48" dia. x 22-29"	32	AAHR48EF	AFHR48EF

PLYWOOD CORE ACTIVITY TABLES

TABLE STYLE	SIZE W x L x H	WT LBS	ADJ. HEIGHT CHROME LEG INSERTS MODEL No	29" FIXED HT POWDERCOATED LEGS MODEL No
Trapezoid	24" x 24" x 48" x 22-29"	27	AATP424EF	AFTP424EF
	30" x 30" x 60" x 22-29"	38	AATP530EF	AFTP530EF
Kidney	48" x 72" x 22-29"	89	AAKY648EF	AFKY648EF
	48" x 96" x 22-29"	119	AAKY848EF	AFKY848EF
Horseshoe	60" x 66" x 22-29"	95	AAHS666EF	AFHS666EF
Clover	48" dia. x 22-29"	51	AAC48EF	AAFC48EF
Flower	60" dia. x 22-29"	77	AAF60EF	AFF60EF

Lower height tables that adjust from 17" to 25" are available upon request. Black metal finish and edge molding are standard. Tops are constructed of solid 47 lb industrial grade particleboard core, edged with vinyl bullnose molding and are 1 1/8" thick.

Adjustable Pedestal Leg

ACTIVITY TABLES



Legs are adjustable in one inch increments.



AP630



AP424F



Support beam is in contact with the underside of the table to prevent sagging.

ADJ. PEDESTAL LEG TABLES Particle Board Top

TABLE STYLE	MODEL No	SIZE W x L x H	WT LBS
Rectangular	AP324F	24" x 36" x 23-30"	52
	AP424F	24" x 48" x 23-30"	66
	AP524F	24" x 60" x 23-30"	79
	AP624F	24" x 72" x 23-30"	88
	AP430F	30" x 48" x 23-30"	72
	AP530F	30" x 60" x 23-30"	89
	AP630F	30" x 72" x 23-30"	102
	AP536F	36" x 60" x 23-30"	102
	AP636F	36" x 72" x 23-30"	119
	AP542F	42" x 60" x 23-30"	126
Trapezoid	APHR530F	30" x 30" x 60" x 23"-30"	64
1/2 Round	APHR60F	60" dia. x 30" x 23"-30"	55
Round	APR48F	48" dia. x 29"	85

ADJ. PEDESTAL LEG TABLES Plywood Top

TABLE STYLE	MODEL No	SIZE W x L x H	WT LBS
Rectangular	AP324EF	24" x 36" x 23-30"	41
	AP424EF	24" x 48" x 23-30"	50
	AP524EF	24" x 60" x 23-30"	60
	AP624EF	24" x 72" x 23-30"	66
	AP430EF	30" x 48" x 23-30"	56
	AP530EF	30" x 60" x 23-30"	66
	AP630EF	30" x 72" x 23-30"	77
	AP536EF	36" x 60" x 23-30"	78
	AP636EF	36" x 72" x 23-30"	88
	AP542EF	42" x 60" x 23-30"	95
Trapezoid	APHR530EF	30" x 30" x 60" x 23"-30"	49
1/2 Round	APHR60EF	60" dia. x 30" x 23"-30"	43
Round	APR48EF	48" dia. x 29"	66

All models are adjustable except round models which are furnished with a fixed height center pedestal and powdercoat finish.



Cafe tables feature easy to assemble, sturdy, cast iron bases that may be matched with the top of your choice. Tops are available in a wide range of attractive, yet durable, high-pressure plastic laminates. Choose the top that suits your environment and budget; economical particleboard core tops with vinyl edge molding or solid plywood core tops with *PermaTuff*, epoxy urethane edge treatment for maximum durability.

CAFE TABLE BASES

MODEL No	SIZE W x L x H	WT LBS
CBR1730	17" dia. x 28"	29
CBR1742	17" dia. x 41"	30
CBR2230	22" dia. x 28"	40
CBR2242	22" dia. x 41"	41
CBR3330	33" dia. x 28"	71
CB2230	22" x 22" x 28"	20
CB3030	30" x 30" x 28"	23
CB52230	5" x 22" x 28"	14
CB52242	5" x 22" x 41"	15
CBLE	Auto 2 1/2" leveling guides	



Available in black finish only. Bases are furnished with manual leveling glides.

BASE SELECTION CHART

Available in 28" and 41" heights

TOP SIZE	4 POINT BASE No	ROUND BASE No	BI-POINT BASE No
24" x 24"	CB2230	CBR1730 CBR1742	
24" x 30"	CB2230	CBR1730 CBR1742	
24" X 72"			CB52230 CB52242
24" X 96"			CB52230 CB52242
30" x 30"	CB2230	CBR1730 CBR1742	
30" x 42"	CB3030	CBR2230 CBR2242	
30" x 48"	CB3030	CBR2230 CBR2242	
36" x 36"	CB3030	CBR3030 CBR2242	
42" x 42"	CB3030	CBR3030 CBR3042	
24" dia.	CB2230	CBR1730 CBR1742	
30" dia.	CB2230	CBR1730 CBR1742	
36" dia.	CB3030	CBR2230 CBR2242	
42" dia.	CB3030	CBR3030	
48" dia.		CBR3030	



CAFE TABLE TOPS

MODEL No	SIZE W x L x H	WT LBS	MODEL No	SIZE W x L x H	WT LBS
Particleboard core, vinyl edge Laminate surface, 1-3/16" thick			Plywood Core, PermaTuff™ edge Laminate Surface, 1-1/16" thick		
T2424F	24" x 24"	21	T2424EFP	24" x 24"	14
T2430F	24" x 30"	28	T2430EFP	24" x 30"	18
T2472F	24" x 72"	75	T2472EFP	24" x 72"	53
T2496F	24" x 96"	102	T2496EFP	24" x 96"	72
T3030F	30" x 30"	36	T3030EFP	30" x 30"	25
T3042F	30" x 42"	53	T3042EFP	30" x 42"	37
T3048F	30" x 48"	62	T3048EFP	30" x 38"	43
T3636F	36" x 36"	55	T3636EFP	36" x 36"	38
T4242F	42" x 42"	77	T4242EFP	42" x 42"	54
TR24F	24" dia.	21	TR24EFP	24" dia.	14
TR30F	30" dia.	36	TR30EFP	30" dia.	25
TR36F	36" dia.	55	TR36EFP	36" dia.	38
TR42F	42" dia.	77	TR42EFP	42" dia.	54
TR48F	48" dia.	102	TR48EFP	48" dia.	72

Standard edge color is black.



2306FA

The right height for each activity is at your fingertips with Midwest snap-lock, adjustable folding leg, activity tables. Independent leg adjustability is made possible by snap locks that adjust on one-inch centers without the use of tools (no screws). Simply press the snap button to release the lock and slide the leg insert to the desired position.



K2306FA
(Junior Ht.)

FA SERIES - HEIGHT ADJUSTMENT



Leg braces incorporate spring loaded, case hardened steel detents for long life and fast set-up & tear-down.

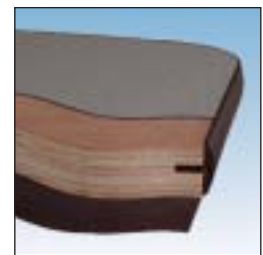

Optional solid 3/4" thick plywood is surfaced with high pressure plastic laminate, sealed with a backing sheet and edged with thick vinyl molding.



To adjust, simply press the snaplock button and slide the leg insert to the desired position.

FA SERIES

TABLE STYLE	MODEL No	SIZE W x L	TABLE HT OPTIONS		Wt LBS
			STANDARD	JUNIOR	
SEMINAR	2185FA	18" x 60"	22"-29"	18"-25"	48
	2186FA	18" x 72"	22"-29"	18"-25"	52
	2188FA	18" x 96"	22"-29"	18"-25"	63
	2245FA	24" x 60"	22"-29"	18"-25"	55
	2246FA	24" x 72"	22"-29"	18"-25"	62
	2248FA	24" x 96"	22"-29"	18"-25"	79
UTILITY	2305FA	30" x 60"	22"-29"	18"-25"	62
	2306FA	30" x 72"	22"-29"	18"-25"	72
	2308FA	30" x 96"	22"-29"	18"-25"	90
	2366FA	36" x 72"	22"-29"	18"-25"	82
	2368FA	36" x 96"	22"-29"	18"-25"	104
PLYWOOD TOP	2305EFA	30" x 60"	22"-29"	18"-25"	50
	2306EFA	30" x 72"	22"-29"	18"-25"	56
	2308EFA	30" x 96"	22"-29"	18"-25"	70
JUNIOR HEIGHT					
RECTANGLE	K2305FA	30" x 60"	22"-29"	18"-25"	58
	K2306FA	30" x 72"	22"-29"	18"-25"	68
	K2308FA	30" x 96"	22"-29"	18"-25"	86
RECTANGLE <i>plywood top</i>	K2305EFA	30" x 60"	22"-29"	18"-25"	46
	K2306EFA	30" x 72"	22"-29"	18"-25"	56
	K2308EFA	30" x 96"	22"-29"	18"-25"	74

Black metal finish is standard on all activity tables.

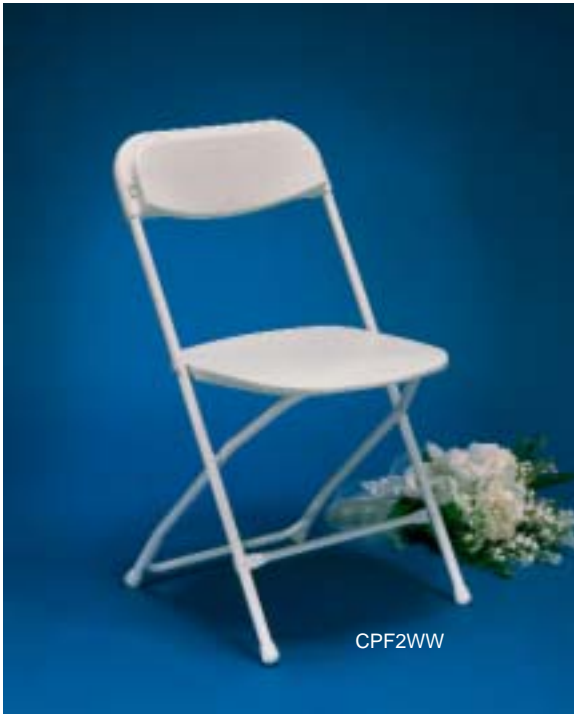

CPF2WW

Midwest's Folding chairs are specially designed for easy handling and compact storage. Their light weight makes it easy to carry a number of chairs at one time to reduce set up and tear down time. Designed to nest when stacked, as many as 68 chairs may be stored and moved on our convenient flat stacking caddy. Up to 120 chairs may be moved and stored on our two-tier caddy for optimum convenience.

Seats and backs are injection molded of resilient, high-impact polypropylene plastic that is easy to clean and durable enough to withstand many years of tough use. Our chip resistant, powdercoated enamel finish protects the frame and makes cleaning easy.



CPF2MC



PLASTIC SEAT & BACK COLORS

DINING PITCH - STANDARD
(auditorium pitch - available)

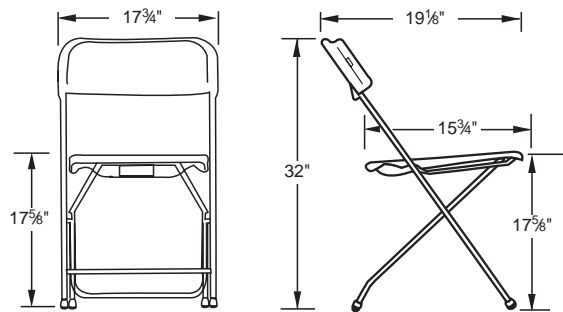

METAL FRAME COLORS



CHAIR STYLE	MODEL No	FRAME COLOR	SEAT BACK COLOR	WT
	CPF2MS	Medium Gray	Slate Blue	6.8
	CPF2MC	Medium Gray	Royal Blue	6.8
	CPF2MR	Medium Gray	Burgundy	6.8
	CPF2MG	Medium Gray	Charcoal	6.8
	CPF2MB	Medium Gray	Black	6.8
	CPF2BB	Black	Black	6.8
	CPF2NN	Neutral	Neutral	6.8
	CPF2NH	Neutral	Chocolate Brown	6.8
	CPF2WW	White	Bright White	6.8
	<i>All stock models are dining pitch. Auditorium pitch available upon request.</i>			
	ACG ARG ARS ARB	Ganger Clip Replacement Glide Replacement Seat Replacement Back		

FOLDING CHAIR CADDIES

TWO TIER CADDY



SINGLE LEVEL CADDY



Model No: CC60
Size: 64"L x 21"W x 38½"H (28-30 cap)
Weight: 53 lbs

Model No: CC72
Size: 76"L x 21"W x 38½"H (34-36 cap)
Weight: 57 lbs

Model No: CC84
Size: 88"L x 21"W x 38½"H (40-42 cap)
Weight: 66 lbs

Model No: CC96
Size: 100"L x 21"W x 38½"H (46-48 cap)
Weight: 70 lbs

OPTIONAL ADJUSTABLE CHAIR SUPPORT

Model No: ACH - For single level caddies
 ACHU - For understage caddies
Weight: 7 lbs

For understage caddies with 22" high handles, add letter U (i.e. CCU60)

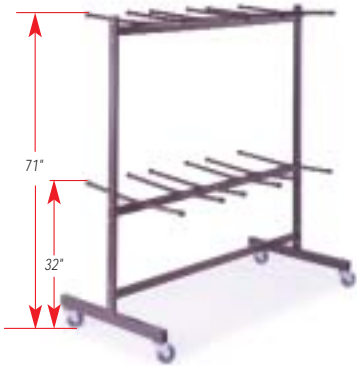

Model No: VCT72
Size: 66"L x 32"W x 71"H (84-120 capacity)
Weight: 95 lbs



POLY CHAIR CADDY

Model No: CCP
Size: 42"L x 20"W x 38"H (68 cap)
Weight: 39 lbs



Chair supports adjust horizontally preventing chairs from falling over as they are transported.

MOBILE UTILITY TABLES



MB306EF



Folds for compact storage



MU306EF

MOBILE UTILITY TABLE WITH RISER SHELF

Model No: MB306EF MB308EF
Size: 30"W x 72"L x 30"H 30"W x 96"L x 30"H
Weight: 108 lbs 130 lbs
 Riser shelf included

INDIVIDUAL RISER SHELF

Model No: SB126EF SB128EF
Size: 12"W x 72"L x 12"H 12"W x 96"L x 12"H
Weight: 22 lbs 35 lbs

Riser shelf may also be used with most folding tables.

Mobile Utility Tables facilitate the display and movement of equipment, supplies, instructional materials, exhibits and classroom demonstrations throughout your facility. Ideal for use in the classroom, cafeteria, media center, gymnasium and office, mobile utility tables eliminate the need for your staff to hand-carry heavy tables. Plastic laminate tops with plywood core construction and heavy-duty steel frames, assure long-term durability.

MOBILE UTILITY TABLE

Model No: MU306EF MU308EF
Size: 30"W x 72"L x 30"H 30"W x 96"L x 30"H
Weight: 86 lbs 95 lbs

HEAVY-DUTY TABLE CADDIES



HRTC

Model No: HRTC
Size: 61"L x 31½"W x 42½"H
Weight: 81 lbs
Capacity: 8 (48"-72" round tables)

HTEC
 61"L x 31½"W x 34½"H
 75 lbs
 8 (rectangular/serpentine tables)



HTC72

Model No: HTC72
Size: 74"L x 31½"W x 41½"H
Weight: 82 lbs
Capacity: 10-12 (24"/30"/36" x 60"/72"L tables)
 20-24 (18"W x 72"L tables)

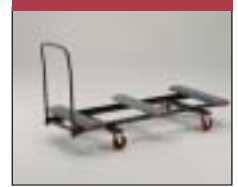

HTC96
 97½"L x 31½"W x 41½"H
 93 lbs
 10-12 (24"/30"/36" x 96"L tables)
 20-24 (18"W x 96"L tables)

STANDARD TABLE CADDIES



RTCHB

Model No: RTCHB
Size: 61"L x 31½"W x 41½"H
Weight: 70 lbs
Capacity: 8 (60"-72" round tables)



RTC

Model No: RTC
Size: 49"L x 31½"W x 41½"H
Weight: 65 lbs
Capacity: 8 (48"-60" round tables)



TC72

Model No: TC72
Size: 74"L x 31½"W x 36½"H
Weight: 67 lbs
Capacity: 10-12 (24"/30"/36" x 60"/72"L tables)
 20-24 (18"W x 72"L tables)



TC96
 97½" x 31½" x 36½"
 78 lb
 10-12 (24"/30"/36" x 96" tables)
 20-24 (18"W x 96"L tables)



TEC

Model No: TEC
Size: 49"L x 31½"W x 32½"H
Weight: 64 lbs
Capacity: 8 (rectangular/serpentine tables)



STANDING CHORAL RISERS

**10
YEAR
WARRANTY**

Modular design allows the flexibility to vary the number of levels to suit the specific needs of each performance. Heavy-duty plywood core deck construction is reinforced by a 16 gauge steel channel frame. Legs of 1.05" diameter, 14 gauge steel tubing are braced with spring-bolt locks to support the heaviest loads with complete safety. Units fold for compact storage and are conveniently stored and transported on double tier caddies.



TAPERED RISERS

GRU36

TRP3C



RISER CADDY

REC

MODEL REC
DESCRIPTION 50"L x 32"W x 45" H
WEIGHT 68 lbs
CAPACITY 24 sections



STRAIGHT RISERS

SRP3H

SRP3H

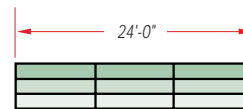
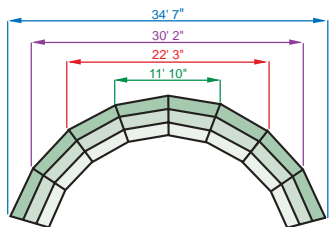

3 sets - SRP3H



TAPERED RISER SETS

LEVELS	CAP.	L x D x H	Hardboard Deck		Polypropylene		Carpet Deck	
			MODEL	Wt	MODEL	Wt	MODEL	Wt
2	9-12	66" x 35" x 16"	TRP2H	72	TRP2P	77	TRP2C	79
3	12-17	72" x 52" x 24"	TRP3H	122	TRP3P	127	TRP3C	131
4	16-22	78" x 69" x 32"	TRP4H	174	TRP4P	182	TRP4C	188

Guardrails are recommended

STRAIGHT RISER SETS

LEVELS	CAP.	L x D x H	Hardboard Deck		Polypropylene		Carpet Deck	
			MODEL	Wt	MODEL	Wt	MODEL	Wt
2	15-19	96" x 35" x 16"	SRP2H	132	SRP2P	136	SRP2C	140
3	20-26	96" x 52" x 24"	SRP3H	202	SRP3P	208	SRP3C	214
4	25-32	96" x 69" x 32"	SRP4H	277	SRP4P	285	SRP4C	293

Guardrails are recommended



Safety tested and listed by Underwriters Laboratories, Midwest mobile stages are safe for use in your facility.

**10
YEAR
WARRANTY**



For added safety our exclusive, automatic latch keeps stage decks locked vertically until you are ready to open the stage for use.



MSW24C

From compact storage to event location, mobile stages save set-up time and increase facility flexibility.

MOBILE STAGES

SIZE		HARDBOARD DECK		POLYPROPYLENE DECK		CARPET DECK	
D x L	Ht	MODEL No	Wt	MODEL No	Wt	MODEL No	Wt
4' x 8'	8"	MS08H	203	MS08P	215	MS08C	227
	16"	MS16H	234	MS16P	246	MS16C	258
	24"	MS24H	254	MS24P	266	MS24C	278
	32"	MS32H	269	MS32P	281	MS32C	303
6' x 8'	8"	MSW08H	222	MSW08P	240	MSW08C	258
	16"	MSW16H	252	MSW16P	270	MSW16C	288
	24"	MSW24H	280	MSW24P	298	MSW24C	316
	32"	MSW32H	295	MSW32P	313	MSW32C	331



Midwest portable stage platforms may be ordered in the same height to assemble a performing stage, or they may be ordered in up to 5 different heights to construct seated band and choral risers. Units fold to store in less than 2" in height when stacked. Dual height models allow easy conversion from seated risers to performing stages when needed. Units are constructed of heavy gauge steel and laminated plywood core decking for unsurpassed safety and durability. Unfold from storage to setup in seconds. Sturdy for long life and rigid for perfect safety. Shipped completely assembled.



The **midwest** Advantage



Stage and riser decks are constructed with solid plywood, laminated with tempered hardboard on top and bottom. Decks are surrounded and supported by 16 gauge formed steel channels for maximum carrying capacity.



Integral drop-in couplings allow stage and riser sections to be ganged together at the same level when set up as a stage, or to be ganged at different levels when set up in a riser arrangement.

DUAL HEIGHT MODELS



Changing heights is easy with our adjustable height mechanism. Just remove the pin, pull out the leg, flip the leg 180°, push the leg back in and re-install the holding pin.

SINGLE HEIGHT UNITS

SIZE		HARDBOARD DECK		POLYPROPYLENE DECK		CARPET DECK	
D x L	Ht	MODEL No	Wt	MODEL No	Wt	MODEL No	Wt
3' x 6'	8"	3608H	68	3608P	71	3608C	74
	16"	3616H	78	3616P	81	3616C	84
	24"	3624H	88	3624P	91	3624C	94
	32"	3632H	98	3632P	101	3632C	104
3' x 8'	8"	3808H	100	3808P	104	3808C	108
	16"	3816H	110	3816P	114	3816C	118
	24"	3824H	120	3824P	124	3824C	128
	32"	3832H	130	3832P	134	3832C	138
4' x 6'	16"	4608H	100	4608P	104	4608C	108
	24"	4616H	105	4616P	109	4616C	113
4' x 8'	16"	4624H	113	4624P	117	4624C	121
	8"	4808H	142	4808P	148	4808C	154
	16"	4816H	147	4816P	153	4816C	159
	24"	4824H	155	4824P	161	4824C	167
4' x 8'	32"	4832H	165	4832P	171	4832C	177
	40"	4840H	180	4840P	186	4840C	192

3' x 4' units are available upon request. Guardrails are recommended for all stages.

DUAL HEIGHT UNITS

SIZE		HARDBOARD DECK		POLYPROPYLENE DECK		CARPET DECK	
D x L	Ht	MODEL No	Wt	MODEL No	Wt	MODEL No	Wt
3' x 8'	8" or 16"	3808DH	120	3808DP	124	3808DC	128
	16" or 24"	3816DH	130	3816DP	134	3816DC	138
	24" or 32"	3824DH	135	3824DP	139	3824DC	143
	32" or 40"	3832DH	140	3832DP	144	3832DC	148
4' x 8'	8" or 16"	4808DH	162	4808DP	168	4808DC	174
	16" or 24"	4816DH	166	4816DP	172	4816DC	178
	24" or 32"	4824DH	170	4824DP	176	4824DC	182
	32" or 40"	4832DH	175	4832DP	181	4832DC	187

3' x 4', 3' x 6', 4' x 4' and 4' x 6' units are available upon request. Guardrails are recommended for all stages.



C600C
Horseshoe Configuration

Portable seated riser sets enhance on-stage performances and help facilitate instruction in the practice room. Sets include all components necessary to construct horseshoe, winged and arc shaped riser configurations. Guardrails are furnished for the uppermost level of the riser set.

Contact Your dealer for a
FREE LAYOUT GUIDE or visit
our web site at
www.midwestfolding.com

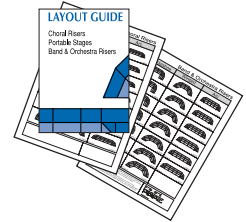

Base Sets

All choral and band layouts below may be constructed from the riser set

Choral Riser Configurations

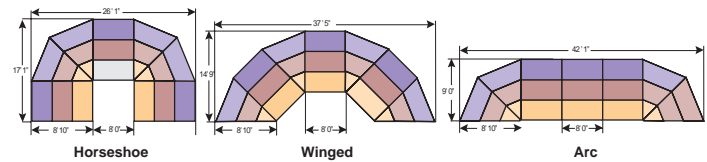

Set Type	Platform Size	Hardboard Deck		Carpet Deck	
		MODEL	WT	MODEL	WT
Choral	36" x 96"	C600H	2198	C600C	2318

Base sets include platforms and pie-shaped sections as shown and rear guard rails.

Straight Riser Sections

Straight riser sections may be used to construct straight riser sets as pictured below or to expand the width and depth of horseshoe, winged and arc shaped riser configurations.



C363C

STRAIGHT RISER SECTIONS

Set Type	Platform Size	Hardboard Deck		Carpet Deck	
		MODEL	WT	MODEL	WT
Choral	36" x 96"	C363H	354	C363C	378
Band	48" x 96"	B483H	468	B483C	504

Three levels – for use at center or ends of riser sets.
Each section includes one each 8", 16" and 24" high platforms and rear guard rails.

Band Riser Configurations

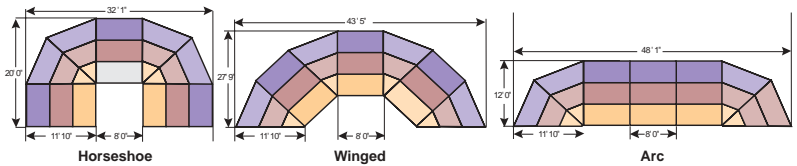

Set Type	Platform Size	Hardboard Deck		Carpet Deck	
		MODEL	WT	MODEL	WT
Band	48" x 96"	B600H	2572	B600C	2804

Base sets include platforms and pie-shaped sections as shown and rear guard rails.



C363C

C363C

C363C



TRP32H

SEATED TAPERED RISER SETS

SIZE L x D x H	HARDBOARD DECK		POLYPROP. DECK		CARPET DECK	
	MODEL	WT	MODEL	WT	MODEL	WT
36" x 60" x 8"	TP08H	57	TP08P	58	TP08C	61
36" x 72" x 16"	TP16H	80	TP16P	83	TP16C	85
36" x 84" x 24"	TP24H	95	TP24P	98	TP24C	101
36" x 96" x 32"	TP32H	110	TP32P	117	TP32C	119

Capacitys include singers seated at floor level.

LAYOUT DIMENSIONS

LEVELS		1 SECTION	2 SECTIONS	3 SECTIONS	4 SECTIONS	5 SECTIONS	6 SECTIONS	7 SECTIONS	8 SECTIONS	9 SECTIONS
1	W x D Cap.	5'0" x 3'0" 5	9'11" x 3'9" 10	14'6" x 4'4" 15	18'9" x 5'7" 20	22'5" x 6'7" 25	25'5" x 8'6" 30	27'10" x 9'11" 35	29'5" x 12'2" 40	30'4" x 13'10" 45
2	W x D Cap.	6'0" x 6'0" 9	11'0" x 6'9" 81	17'3" x 7'4" 27	22'4" x 8'9" 36	26'9" x 9'7" 45	30'6" x 11'7" 54	33'6" x 12'11" 63	35'6" x 15'3" 72	36'6" x 16'10" 81
3	W x D Cap.	7'0" x 9'0" 13	13'10" x 9'10" 26	20'4" x 10'4" 39	26'2" x 11'9" 52	31'3" x 12'9" 65	35'8" x 14'8" 78	38'10" x 16'2" 91	41'0" x 18'4" 104	42'3" x 12'9" 117
4	W x D Cap.	8'0" x 12'0" 18	15'9" x 13'0" 36	23'2" x 13'4" 54	30'0" x 14'9" 72	35'10" x 15'10" 90	40'9" x 17'8" 108	44'6" x 19'2" 126	47'0" x 21'6" 144	48'6" x 23'2" 162



ACCESSORIES AND COLOR SELECTION

SKIRTING COLORS

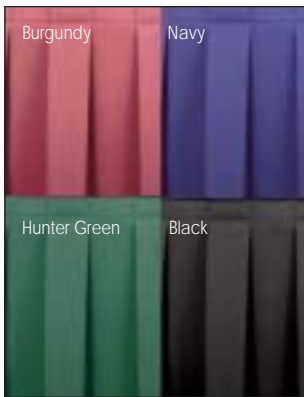

Box pleat skirting of fire retardant twill fabric is Velcro® backed for easy attachment to the stage perimeter.

SKIRTING

MODEL	Ht	Wt
SKB08	8"	0.1
SKB16	16"	0.2
SKB24	24"	0.3
SKB32	32"	0.4
SKB40	40"	0.4

Mating Velcro® must be ordered separately for stages and risers.



Factory installed Velcro® available upon request.

STAGE AND RISER CADDY



SC

Convenient caddies transport stages & risers to the event location and safely hold each unit until legs are folded open and the unit is rotated to the floor. Holds 6 units.

DECK FINISHES



Hardboard
Carpet
Black Polypropylene
Gray Polypropylene



ST1

ST2

ST3

ST4

Steps are surfaced with slip resistant, gray polypropylene. Units clamp securely to any area of the stage perimeter. Wheels are furnished on two and three step units for easy handling.

PORTABLE STEP UNITS

MODEL	W x D x H	Wt	FOR USE WITH
ST1 (1 step)	36" x 14" x 47"	20	8" & 16" high stages
ST2 (2 step)	36" x 27" x 16"	39	16" & 24" high stages
ST3 (3 step)	36" x 40" x 24"	58	24" & 32" high stages
ST4 (4 step)	36" x 52" x 32"	77	32" & 40" high stages

All steps are 12" deep by 34" wide.

METAL FINISH COLORS

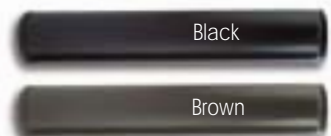

Unless otherwise specified, brown metal color is standard with all mushroom tan carpeted surfaces and hardboard surfaces. Black metal color is standard with all other carpeted and polypropylene surfaces.

CARPET COLORS



Pewter Gray

Mushroom Tan

Twilight Blue

Rainforest Green

Fiesta Red

Charcoal Gray



midwest **FOLDING PRODUCTS**
A SAGUS INTERNATIONAL COMPANY

1414 S. Western Avenue
Chicago, Illinois 60608
312-666-3366
800-621-4716
Fax 312-666-2606

Visit us at
www.midwestfolding.com

